

**Revision A:**

- Parts numbers have been changed.

Please void OBB683.

# INDOOR UNIT PARTS CATALOG

**No. OBB683**  
REVISED EDITION-A

## Models

**MSZ-FH09NA**  
**MSZ-FH12NA**  
**MSZ-FH15NA**

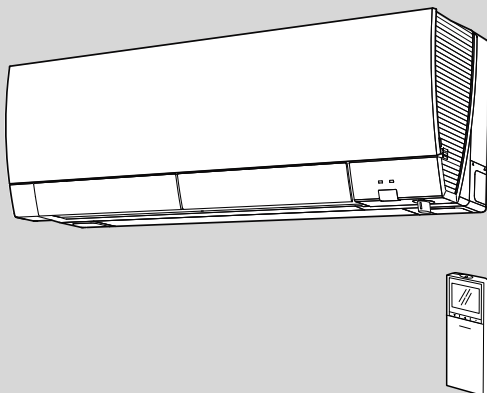

## CONTENTS

1. RoHS PARTS LIST..... 2

**SERVICE MANUAL (OBH683)**

**NOTE:**

RoHS compliant products have <G> mark on the spec name plate.

**Revision A:**

• Parts numbers have been changed.

**1 RoHS PARTS LIST**

**MSZ-FH09NA MSZ-FH12NA MSZ-FH15NA**  
**1-1. INDOOR UNIT STRUCTURAL PARTS**

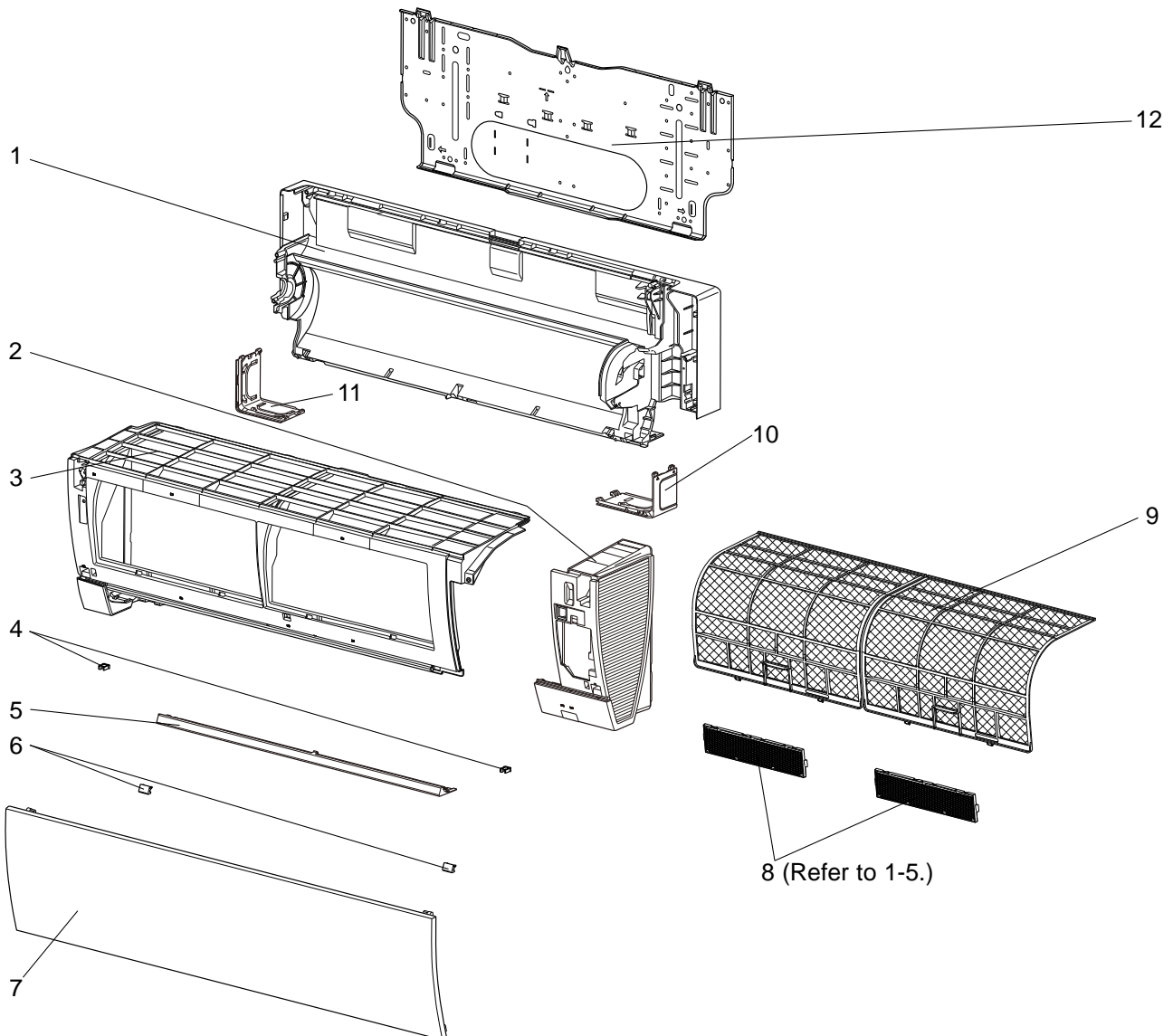

**1-2. ACCESSORY AND REMOTE CONTROLLER**

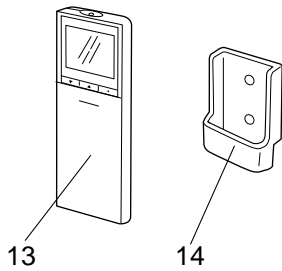

# RoHS PARTS LIST

## 1-1. INDOOR UNIT STRUCTURAL PARTS

No.	RoHS	Part No.	Part name	Symbol in Wiring Diagram	Q'ty/unit			Remarks
					MSZ-FH			
					09NA	12NA	15NA	
1	G	E12 J46 234	BOX ASSEMBLY		1	1	1	
2	G	E12 L85 085	PANEL RIGHT ASSEMBLY		1	1	1	
3	G	E12 J44 086	PANEL LEFT ASSEMBLY		1	1	1	
4	G	E12 F95 142	CATCH		2	2	2	2 PCS/SET
5	G	E12 J44 717	PANEL UNDER		1	1	1	
6	G	E12 J44 067	SCREW CAP		2	2	2	2 PCS/SET
7	G	E12 J44 010	FRONT PANEL		1	1	1	
8	G	—	AIR CLEANING FILTER (ELECTROSTATIC ANTI-ALLERGY ENZYME FILTER)		1	1	1	1 PC/SET MAC-2330FT-E
	G	—	AIR CLEANING FILTER (DEODORIZING FILTER)		1	1	1	1 PC/SET MAC-3000FT-E
9	G	E12 L85 100	NANO PLATINUM FILTER		2	2	2	1 PC/SET
10	G	E12 J44 975	CORNER BOX RIGHT		1	1	1	
11	G	E12 J44 976	CORNER BOX LEFT		1	1	1	
12	G	E12 L85 970	INSTALLATION PLATE		1	1	1	

## 1-2. ACCESSORY AND REMOTE CONTROLLER

No.	RoHS	Part No.	Part name	Symbol in Wiring Diagram	Q'ty/unit			Remarks
					MSZ-FH			
					09NA	12NA	15NA	
13	G	E12 L85 426	REMOTE CONTROLLER		1	1	1	SG14A
14	G	E12 F28 083	REMOTE CONTROLLER HOLDER		1	1	1	

# RoHS PARTS LIST

MSZ-FH09NA MSZ-FH12NA MSZ-FH15NA

## 1-3. INDOOR UNIT ELECTRICAL PARTS AND FUNCTIONAL PARTS

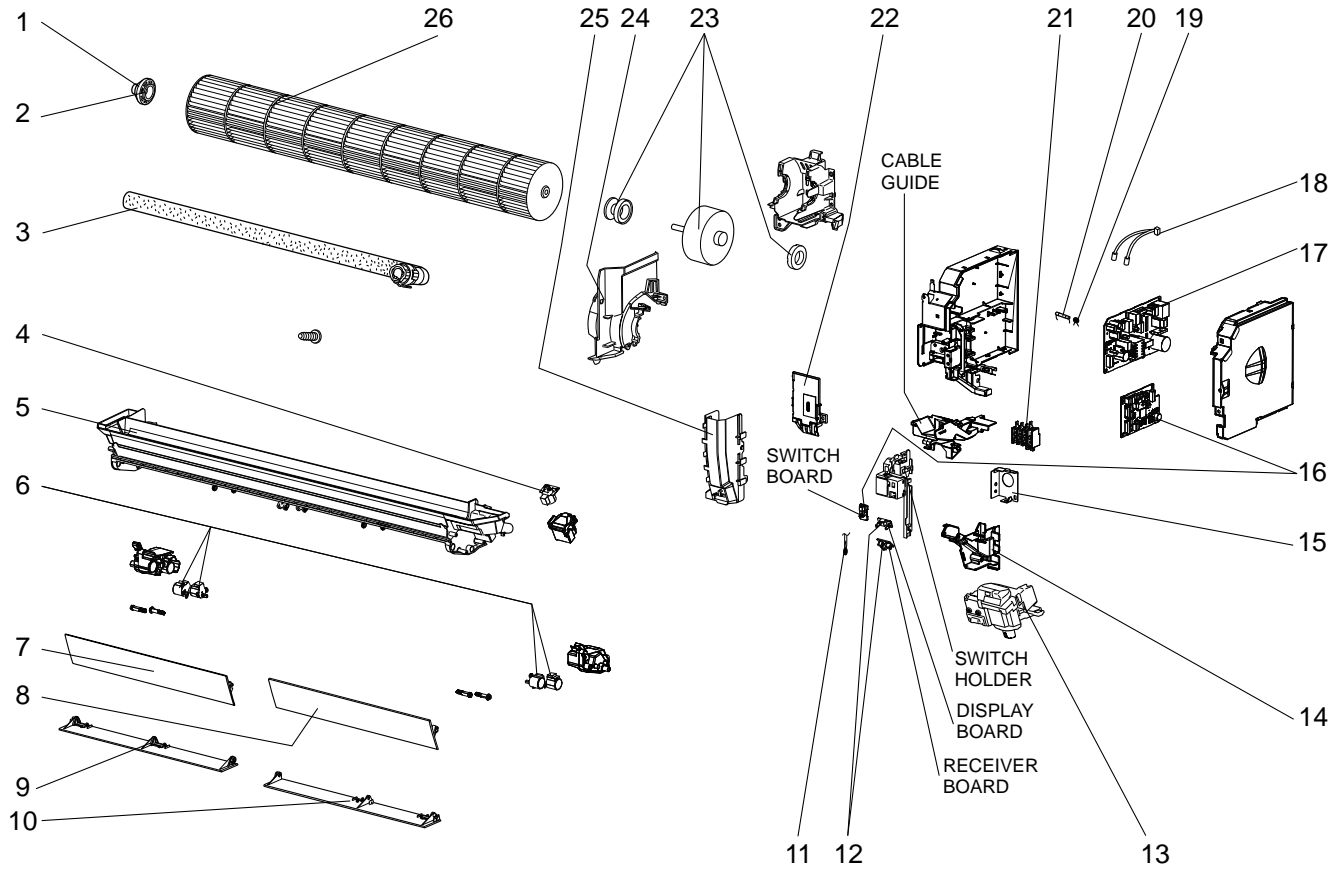

# RoHS PARTS LIST

## 1-3. INDOOR UNIT ELECTRICAL PARTS AND FUNCTIONAL PARTS

No.	RoHS	Part No.	Part name	Symbol in Wiring Diagram	Q'ty/unit			Remarks
					MSZ-FH			
					09NA	12NA	15NA	
1	G	E12 751 509	BEARING MOUNT		1	1	1	
2	G	E12 001 504	SLEEVE BEARING		1	1	1	
3	G	E12 897 702	DRAIN HOSE		1	1	1	
4	G	E12 J44 303	VANE MOTOR (VERTICAL)	MV2	1	1	1	RIGHT & LEFT
5	G	E12 L85 235	NOZZLE ASSEMBLY		1	1	1	
6	G	E17 103 303	VANE MOTOR (HORIZONTAL)	MV1	4	4	4	UP & DOWN, 1 PC/SET
7	G	E12 J45 040	VANE UPPER (L)		1	1	1	
8	G	E12 J44 040	VANE UPPER (R)		1	1	1	
9	G	E12 J45 041	VANE LOWER (L)		1	1	1	
10	G	E12 J44 041	VANE LOWER (R)		1	1	1	
11	G	E12 J44 308	ROOM TEMPERATURE THERMISTOR	RT11	1	1	1	
12	G	E12 J44 468	DISPLAY AND RECEIVER P.C. BOARD		1	1	1	
13	G	E12 J44 391	DISPLAY AND i-see SENSOR ASSEMBLY ※1		1	1	1	
14	G	E12 L85 979	CONDUIT COVER		1	1	1	
15	G	E12 L85 978	CONDUIT PLATE		1	1	1	
16	G	E12 L85 452	ELECTRONIC CONTROL P.C. BOARD ※2		1			
	G	E12 L86 452				1		
	G	E12 L87 452					1	
17	G	E12 L85 440	POWER P.C. BOARD		1	1	1	
18	G	E12 J44 307	INDOOR COIL	RT12,RT13	1	1		
	G	E12 L87 307	THERMISTOR				1	
19	G	E12 B75 385	VARISTOR	NR11	1	1	1	
20	G	E12 A49 382	FUSE	F11	1	1	1	T3.15AL250V
21	G	E12 F95 375	TERMINAL BLOCK	TB	1	1	1	
22	G	E12 L85 784	V.A. CLAMP		1	1	1	
23	G	E12 J44 300	INDOOR FAN MOTOR ※3	MF	1	1	1	RC0J30-□□
24	G	E12 J46 333	MOTOR BAND		1	1	1	
25	G	E12 J44 541	WATER CUT		1	1	1	
26	G	E12 J44 302	LINE FLOW FAN		1	1	1	

※1 Including i-see SENSOR and i-see SENSOR MOTOR (MT).

※2 Including SWITCH P.C. BOARD

※3 Including FAN MOTOR RUBBER MOUNT (2 PCS/SET)

# RoHS PARTS LIST

MSZ-FH09NA MSZ-FH12NA MSZ-FH15NA

## 1-4. INDOOR UNIT HEAT EXCHANGER

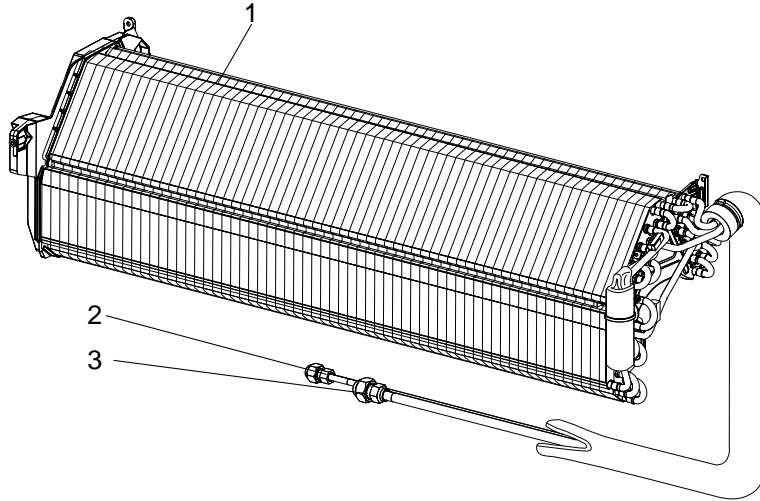

No.	RoHS	Part No.	Part name	Symbol in Wiring Diagram	Q'ty/unit			Remarks
					MSZ-FH			
					09NA	12NA	15NA	
1	G	E12 L85 620	INDOOR HEAT EXCHANGER		1	1		
	G	E12 L87 620					1	
2	G	E12 151 667	UNION (LIQUID)		1	1	1	ø1/4 (ø6.35)
3	G	E12 815 666	UNION (GAS)		1	1		ø3/8 (ø9.52)
	G	E12 155 666					1	ø1/2 (ø12.7)

# RoHS PARTS LIST

## 1-5. AIR CLEANING FILTER

### Air cleaning filter replacement

Pull to remove from the air filter

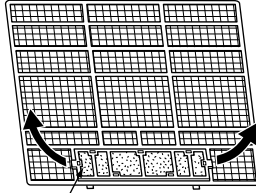

Air cleaning filter

- Electrostatic anti-allergy enzyme filter (Blue)
- Deodorizing filter (Black)

### ELECTROSTATIC ANTI-ALLERGY ENZYME FILTER (BLUE)

**Every 3 months:**

- Remove dirt by a vacuum cleaner.

**When dirt cannot be removed by vacuum cleaning:**

- Soak the filter and its frame in lukewarm water before rinsing it.
- After washing, dry it well in shade. Install all tabs of the air filter.

**Every year:**

- Replace it with a new air cleaning filter for best performance.

**NOTE 1:** Clean the filters regularly for best performance and to reduce power consumption.

**NOTE 2:** Dirty filters cause condensation in the air conditioner which will contribute to the growth of fungi such as mold. It is therefore recommended to clean air filters every 2 weeks.

Model	Part No.
MSZ-FH09NA MSZ-FH12NA MSZ-FH15NA	MAC-2330FT-E

### DEODORIZING FILTER (BLACK)

**Every 3 months:**

- Remove dirt by a vacuum cleaner, or soak the framed filter in lukewarm water [ 86 to 104°F (30 to 40 °C)] for about 15 minutes. Rinse well.
- After washing, dry it well in shade.
- Deodorizing feature recovers by cleaning the filter.

**When dirt or smell cannot be removed by cleaning:**

- Replace it with a new air cleaning filter.

Model	Part No.
MSZ-FH09NA MSZ-FH12NA MSZ-FH15NA	MAC-3000FT-E

# **mitsubishi electric corporation**

HEAD OFFICE: TOKYO BLDG., 2-7-3, MARUNOUCHI, CHIYODA-KU, TOKYO 100-8310, JAPAN

© Copyright 2014 MITSUBISHI ELECTRIC CORPORATION  
Distributed in Apr. 2014. No. OBB683 REVISED EDITION-A  
Distributed in Feb. 2014. No. OBB683  
Made in Japan

New publication, effective Apr. 2014  
Specifications are subject to change without notice.